

Express AMU2

Frequency Plan C-Band

Uplink

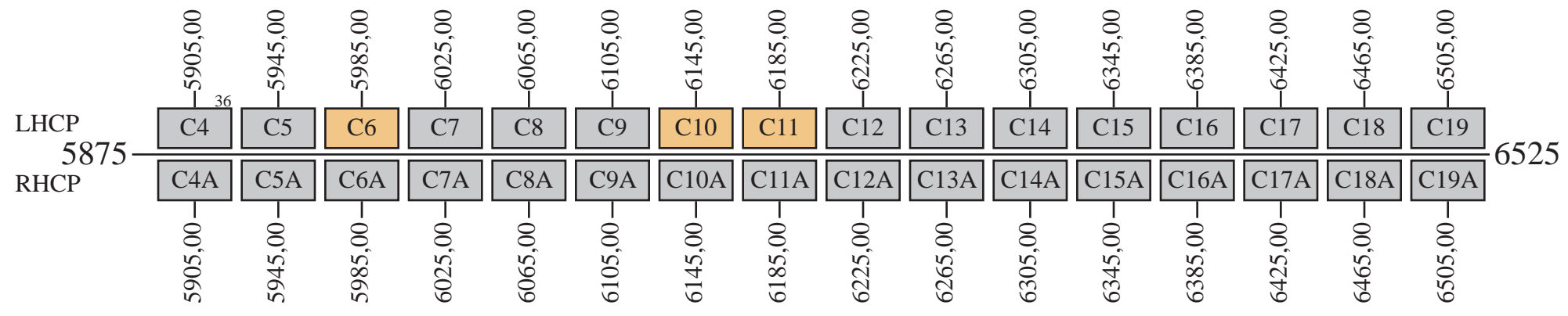

Downlink

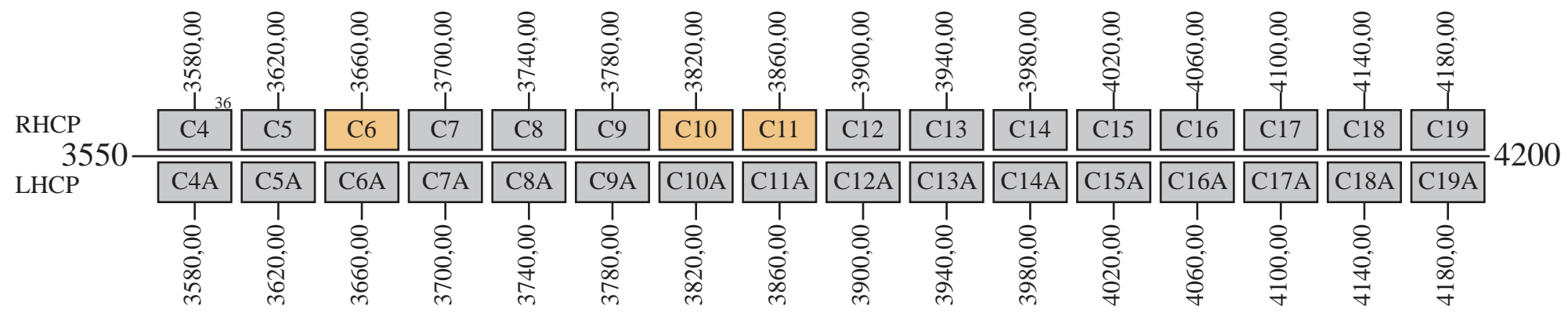

Fixed Beam
 Fixed or Global Beam

Beacon 1: 3760,00 R Global
 Beacon 2: 3760,50 L Global
 Beacon 3: 11700,00 H Global
 Beacon 4: 11699,50 V Global

Express AMU2

Frequency Plan Ku-Band

Uplink

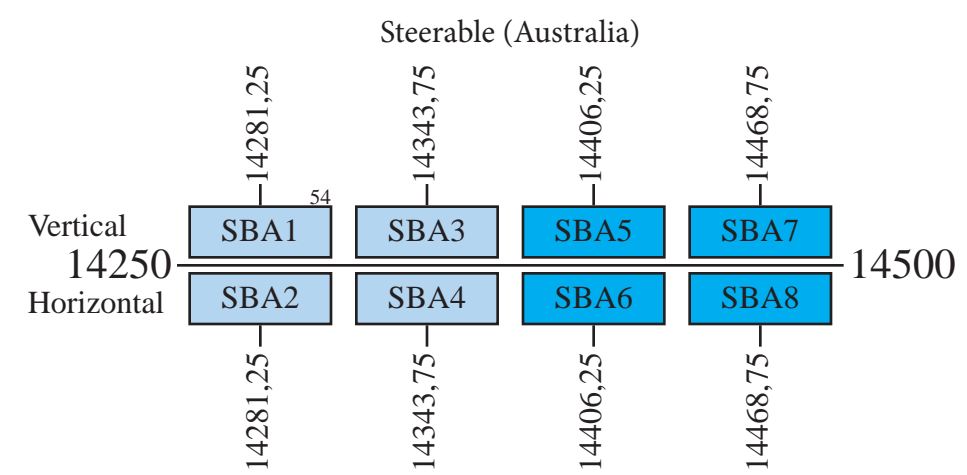
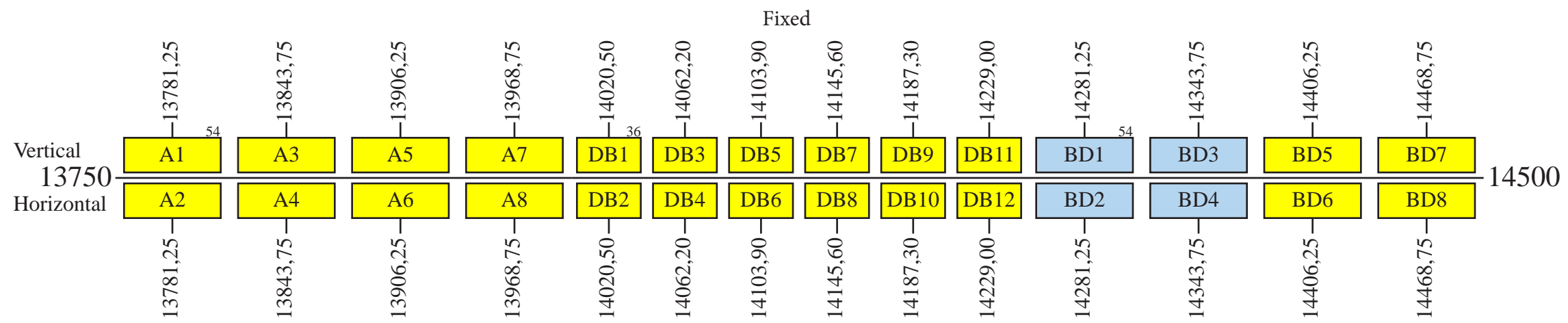

Downlink

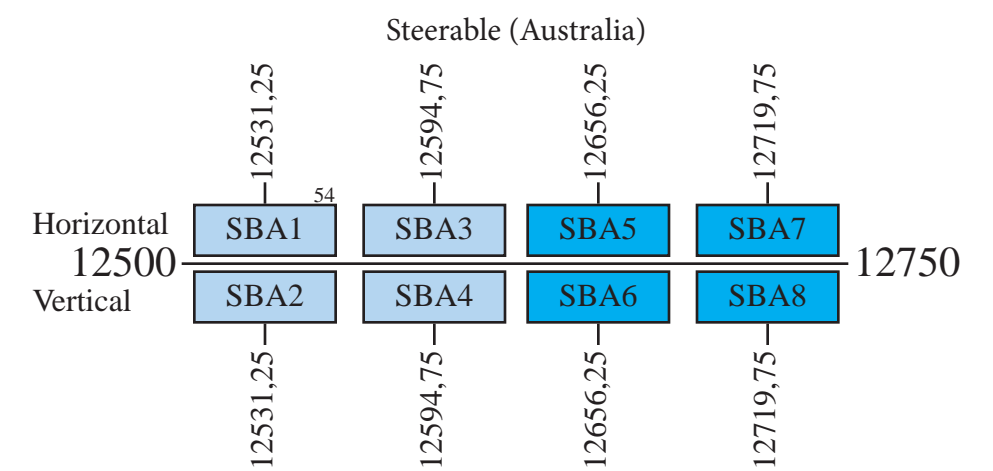
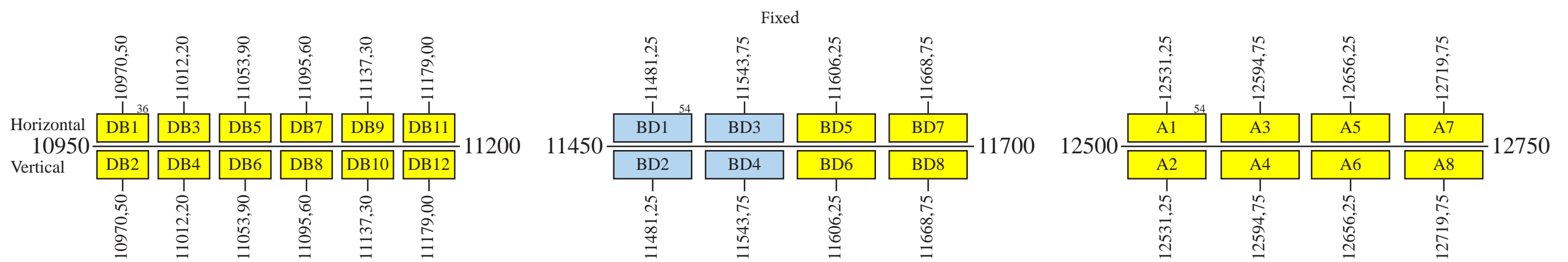

Notes: 1) The transponders (DB1, DB2, DB3 and DB4) can receive the uplink coverage from fixed (DB1, DB2, DB3 and DB4) or Steerable (SBA1, SBA2, SBA3 and SBA4) switchable channel by channel.
 2) The transponders (SBA1, SBA2, SBA3 and SBA4) can receive the uplink coverage from Steerable (SBA1, SBA2, SBA3 and SBA4) or Fixed (DB1, DB2, DB3 and DB4) switchable channel by channel.